



Signal Processing Techniques in 5G Technology

Disni Jose M¹, Shahaziya Parvez M², Anitha M³

^{1,2} Assistant Professor, Department of Robotics and AI, IES College of Engineering, Thrissur, India

³ Lab Instructor, Department of Robotics and AI, IES College of Engineering, Thrissur, India

Email_id: disnijack@gmail.com, parvez25290@gmail.com, anithaamadhav@gmail.com

Abstract

The advent of 5G technology has brought forth a paradigm shift in wireless communication, promising unprecedented data rates, ultra-low latency, and massive connectivity. At the heart of 5G lies advanced signal processing techniques, which play a pivotal role in realizing its ambitious goals. This paper presents a comprehensive review of the key signal processing techniques employed in 5G networks. Beginning with an overview of the fundamental principles of 5G communication systems, encompassing Massive Multiple-Input Multiple-Output (Massive MIMO), 3D beamforming and diversity, and Orbital Angular Momentum (OAM)-based multiplexing. The discussion delves into the intricacies of these techniques, highlighting their role in enhancing spectral efficiency, capacity, and reliability in next generation wireless systems. Techniques emerging technologies in 5G, such as millimeter-wave communications, cloud radio access networks (C-RAN), full-duplex mode operation, and digital radio-frequency processing. The discussion of these emerging techniques offers insights into the evolving landscape of 5G signal processing and its potential implications for future network architectures and applications. Moreover, this review discusses the challenges and research directions in signal processing for future 5G enhancements, including machine learning-based approaches and cooperative signal processing strategies. By synthesizing insights from recent research advancements and standardization efforts, this review provides a comprehensive understanding of the signal processing landscape in 5G technology, paving the way for future innovations and deployments in next-generation wireless networks.

Keywords: 5G, Signal Processing, GFDM, Massive MIMO, 3D Beamforming, Spatial Multiplexing

DOI: <https://doi.org/10.5281/zenodo.19506345>

1. Introduction

Signal processing techniques have played a pivotal role in shaping the landscape of wireless communications since the advent of the second generation (2G) of cellular systems. Each successive generation, spanning from 2G through to 4G, has been characterized by a dominant metric for performance improvement. For instance, 2G systems were distinguished by the adoption of time-division multiple access (TDMA), while code-division multiple access (CDMA) marked the advancements in 3G technology. In 4G, orthogonal frequency-division multiple access (OFDMA) emerged as the defining signal processing technology. However, the trajectory shifts with the advent of fifth-generation (5G) systems. Unlike its predecessors, 5G does not adhere to a single dominant performance metric instead, it is characterized by a diverse set of requirements and objectives. In this new era, the focus extends beyond merely increasing peak service rates. 5G systems are tasked with significantly enhancing capacity, coverage,

efficiency (in terms of power, spectrum, and other resources), flexibility, compatibility, and convergence. These imperatives stem from the burgeoning demands of emerging applications such as big data, cloud services, and machine-to-machine (M2M) communication. To meet these multifaceted challenges, a plethora of novel signal processing techniques has been proposed and is currently under consideration for international standardization and deployment within 5G networks. This article aims to provide an overview of these promising signal processing techniques, from both practical and standardization perspectives. It places particular emphasis on orthogonal and non-orthogonal modulation techniques, which are pivotal for accommodating the diverse requirements of 5G networks. Additionally, the discussion extends to spatial processing techniques, including massive multiple-input multiple-output (massive MIMO), three-dimensional beamforming and diversity, and multiplexing based on orbital angular momentum (OAM). These techniques represent critical avenues for enhancing the performance and capabilities of 5G wireless communication systems in the face of evolving demands and applications.

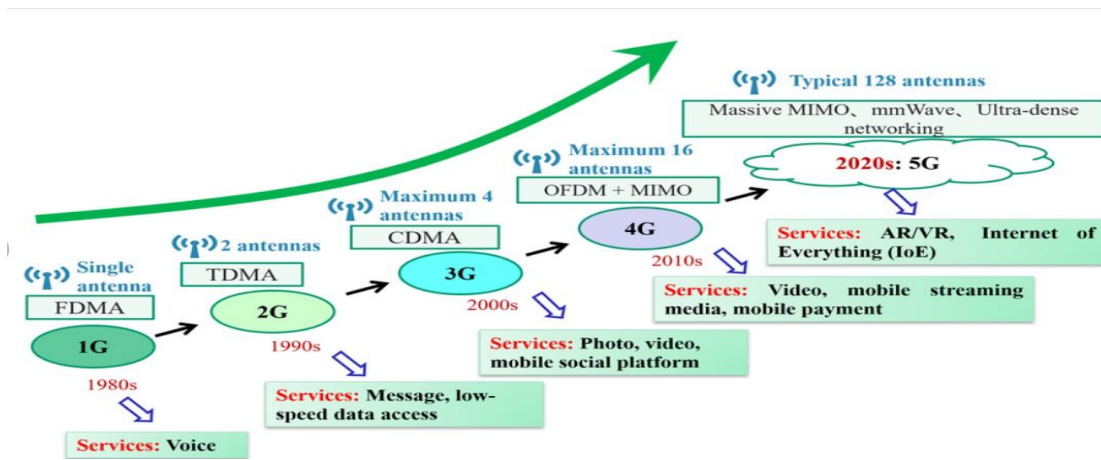

Figure 1: 1G-5G: Antennas, multiple access technologies, and services.

This figure 1 illustrates the evolution of wireless communication technologies from 1G to 5G, focusing on key aspects such as antennas, multiple access technologies, services, and notable technological advancements. 1G, representing the first generation, is characterized by the use of omni-directional antennas and the adoption of analog technologies. Multiple access technologies include Frequency Division Multiple Access (FDMA) and Time Division Multiple Access (TDMA), primarily facilitating voice calling services. Moving to 2G, directional antennas are introduced, improving signal quality and coverage. Digital technologies become prominent, with TDMA and Code Division Multiple Access (CDMA) being the main multiple access technologies. This generation sees the addition of Short Messaging Services (SMS) alongside voice calls. 3G introduces smart antennas and Wideband CDMA (WCDMA) and CDMA2000, enhancing data services and enabling features like video calling and multimedia messaging. In the 4G era, Multiple-Input Multiple-Output (MIMO) antennas are deployed, along with Orthogonal Frequency Division Multiple Access (OFDMA) and Single Carrier Frequency Division Multiple Access (SC-FDMA) for efficient resource allocation and high-speed mobile broadband services. Finally, 5G networks leverage massive MIMO, beamforming, and millimeter-wave technology to achieve ultra-fast data rates and low latency. Advanced

multiple access technologies such as Non-Orthogonal Multiple Access (NOMA) and Multi-User MIMO (MU-MIMO) are employed, enabling diverse services like enhanced mobile broadband (eMBB), ultra-reliable low latency communications (URLLC), and massive machine-type communications (mMTC). Notable technological advancements in 5G include massive MIMO, beamforming, and the utilization of millimeter-wave spectrum.

Paper structure: The remainder of the paper is organized as follows. In Section II evaluate the research papers, In Section III gives Signal Processing Algorithms for Modulation, In Section IV describes about signal processing techniques in 5G, In Section V is about challenges and opportunities, In Section VI provides the conclusion about the paper.

2. Literature Survey

F.L. Luo, W. Williams, M. R. Rao[1] the provided excerpt discusses modulation processing techniques in the context of wireless communication systems, particularly focusing on Orthogonal Frequency Division Multiplexing (OFDM) and Orthogonal Frequency Division Multiple Access (OFDMA), which are commonly used in 4G systems. It outlines the advantages and disadvantages of OFDM and OFDMA, highlighting their effectiveness in mitigating interference and providing robustness against inter-symbol interference and multipath distortion. However, it also acknowledges their limitations, such as high peak-to-average power ratio (PAPR), limited spectral efficiency, and sensitivity to frequency offsets and phase noise.

Furthermore, the excerpt mentions that these drawbacks have led to the investigation of more advanced modulation schemes for 5G systems, including Generalized Frequency Division Multiplexing (GFDM), Filter-Bank Multi-carrier (FBMC), Universal Filtered Multicarrier (UFMC), Bi-Orthogonal Frequency Division Multiplexing (BFDM), Sparse Code Multiple Access (SCMA), and Non-Orthogonal Multiple Access (NOMA). These schemes offer potential solutions to overcome the limitations of OFDM and OFDMA, thereby addressing the evolving requirements of 5G networks. comprehensive review of Multi-User Multiple Input Multiple Output (MIMO) technology, particularly focusing on the advantages and challenges associated with Massive MIMO. Multi-user MIMO is highlighted as a significant advancement over traditional point-to-point MIMO systems, primarily due to its compatibility with cost-effective single-antenna terminals and simplified resource allocation. However, it also acknowledges that traditional multi-user MIMO approaches may not be scalable.

E. G. Larsson [2] explained the transformative potential of Massive MIMO, which represents a departure from conventional practices by employing a large excess of service antennas over active terminals and utilizing time-division duplex operation. This approach enables significant improvements in throughput and radiated energy efficiency by focusing energy into smaller spatial regions. Additionally, Massive MIMO offers benefits such as the use of inexpensive low-power components, reduced latency, simplified MAC layer, and resilience against intentional jamming.

Furthermore, highlights several new challenges introduced by Massive MIMO, including the integration of low-cost low-precision components, acquisition and synchronization for newly joined terminals, utilization of additional degrees of freedom provided by excess service antennas, reduction of internal power consumption, and exploration of new deployment scenarios.

Overall, provides valuable insights into the potential of Massive MIMO technology to revolutionize wireless communication systems. It underscores the need for further research and development to address the emerging challenges and fully realize the benefits of this innovative approach.

F. Rusek, D. Persson, B. K. Lau, et al[3]. the findings suggest that Multiple-Input Multiple-Output (MIMO) technology is advancing and becoming an integral part of emerging wireless broadband standards, such as Long-Term Evolution (LTE). These standards are evolving to accommodate increasingly higher numbers of antenna ports at base stations, with LTE supporting up to eight antenna ports. The performance of MIMO systems is directly influenced by the number of antennas employed by both the transmitter and receiver, as well as the degrees of freedom provided by the propagation channel.

In quasi-static channel conditions, where a code word spans only one time and frequency coherence interval, the reliability of a point-to-point MIMO link is determined by the signal-to-noise ratio (SNR) and scales according to the product of the numbers of transmit and receive antennas (n_t and n_r , respectively). However, on channels that exhibit rapid variations in time and frequency, and allow for coding across multiple coherence intervals, the achievable data rate scales according to the minimum of n_t and n_r , multiplied by the logarithm of one plus the SNR.

Moreover, the findings underscore the significant benefits of MIMO technology in multiuser systems. These systems offer the capability to transmit simultaneously to multiple users, as well as the flexibility to dynamically select which users to schedule for reception at any given moment. Consequently, the gains achieved in multiuser MIMO systems are even more remarkable, further enhancing data rates and link reliability compared to point-to-point MIMO configurations.

Overall, these findings highlight the importance of MIMO technology in enhancing the performance and efficiency of wireless communication systems, particularly in terms of data rates and link reliability, and emphasize its continued evolution and integration into emerging broadband standards.

S. Mohammad Razavizadeh, M. Ahn, and I. Lee focused a technique called 3D Beamforming (3DBF) as a potential method for enhancing 5G wireless systems. This technique adjusts the radiation beam pattern both vertically and horizontally, giving more flexibility in how the system is designed. Compared to the traditional 2D Beamforming (2DBF), 3DBF offers several advantages such as increased user capacity and reduced interference between cells and sectors. Using mathematical modeling of the 3D antenna pattern, researchers conducted Monte Carlo simulations to evaluate its performance compared to 2DBF. The results of these simulations showed that 3DBF performs better than 2DBF. Therefore, it's anticipated that 3DBF will be a critical component in designing 5G systems.

O. Edfors and A. J. Johansson[12] demonstrates that OAM- based radio communication can be obtained from standard MIMO theory under specific conditions. A system design with UCAs facing each other on the same beam axis in free space results in circulant channel matrices, which are diagonalized by the DFT. The OAM states are a set of eigen-modes of these channels. The system's performance is evaluated, showing that above the Rayleigh distance, there is a single dominant eigen-mode/OAM state, leading to small capacity gain and no multiplexing gain. However, below the Rayleigh distance, the systems almost achieve the maximum capacity gains predicted by MIMO theory when using OAM- based eigenmodes. This makes UCAs a relatively good choice for free-space

communication, as there is little extra gain to achieve with other array geometries.

A. G. Timoshenko; N. K. Osipenko[11] discusses the implementation of 5G signals on USRP-2943R, revealing options for reducing peak-factor with increasing out-of-band emissions. New signal generation schemes resulted in a loss of 8 dB compared to classic UFMC and F-OFDM, but a problem with LUT approach due to rude PA saturation was discovered.

2.1. GFDM (Generalized Frequency Division Multiplexing): GFDM is a multi-carrier modulation scheme that aims to overcome some of the limitations of OFDM. It introduces additional degrees of freedom in terms of filtering and wave- form design. GFDM utilizes filter banks to enable overlapping subcarriers in frequency domain, allowing for better spectral containment and improved interference management. It is particularly suited for scenarios with stringent requirements on spectral efficiency and coexistence with other systems.[16]

2.2. FBMC (Filter Bank Multicarrier): FBMC is another alternative to OFDM that employs a filter bank at the trans- mitter and receiver. Unlike OFDM, where each subcarrier is independently modulated, FBMC processes multiple subcarri-ers simultaneously through a filtering operation. This results in a more efficient use of spectrum and better resilience to frequency-selective fading. FBMC is especially attractive for applications requiring low latency and high spectral efficiency, such as in 5G and beyond[16].

2.3. UFMC (Universal Filtered Multicarrier): UFMC is similar to FBMC in that it employs filtering to shape the transmitted signals. However, UFMC uses a different filter structure that offers a balance between spectral containment and out-of-band emissions. UFMC is designed to be more flexible and adaptable to different deployment scenarios compared to traditional OFDM. It provides improved spectral efficiency and robustness against narrowband interference, making it a promising candidate for future wireless systems.[17].

2.4. BFDM (Block Filtered Multicarrier): BFDM is a modulation scheme that divides the frequency spectrum into blocks and applies filtering techniques to each block individually. By doing so, BFDM can achieve better spectral containment and reduced interference compared to OFDM. It offers increased flexibility in waveform design and can adapt to various channel conditions and system requirements. BFDM has been proposed as a potential alternative to OFDM for next-generation wireless communication systems.

2.5. SCMA (Sparse Code Multiple Access): SCMA is a non-orthogonal multiple access scheme that allows multiple users to share the same frequency resources by using sparse codebooks. Each user is assigned a unique sparse codebook, and the transmitted signals are designed to be distinguishable at the receiver despite overlapping in the frequency domain. SCMA offers higher spectral efficiency and improved user capacity compared to traditional orthogonal multiple access schemes like OFDMA. It is particularly suitable for scenarios with a large number of connected devices and varying traffic demands.[15]-[20].

2.6. NOMA (Non-Orthogonal Multiple Access): NOMA is a multiple access technique that allows multiple users to share the same time-frequency resources by allocating different power levels or using superposition coding. Unlike orthogonal multiple access schemes where users are assigned orthogonal resources, NOMA exploits the power domain to enable simultaneous transmission. This allows for better resource utilization and higher throughput. NOMA has gained significant attention for its potential to enhance spectral efficiency and support massive connectivity in future

wireless networks.[13]

3. Signal Processing Algorithms for Modulation

Modulation processing in wireless systems involves altering signal waveforms using data, impacting various system factors such as transmission speed, spectral efficiency, power consumption, and more. OFDM and OFDMA, prevalent in 4G systems, offer advantages like interference elimination, ease of implementation, power adaptation, and robustness against interference. However, they suffer from drawbacks such as high peak-to-average power ratio (PAPR), limited spectral efficiency, and sensitivity to frequency offsets and phase noise. These disadvantages prevent OFDMA schemes from being immediately used in 5G systems, and more advanced modulation schemes, such as GFDM, FBMC, UFMC, BFD, SCMA, and NOMA, have been explored. A. G. Timoshenko, N. K. Osipenko, A. A. Bakhtin [11] discusses the implementation of 5G signals on USRP-2943R, revealing options for reducing peak-factor with increasing out-of-band emissions. New signal generation schemes resulted in a loss of 8 dB compared to classic UFMC and F-OFDM, but a problem with LUT approach due to rude PA saturation was discovered.

4. Signal Processing Techniques In 5G

Spatial-domain signal processing techniques like MIMO, beamforming, and antenna diversity have been predominantly utilized in 4G and digital broadcasting systems.[1] In 5G, these spatial signal processing techniques are undergoing further enhancements, with the development of new algorithms such as massive MIMO and three-dimensional beamforming. These advancements aim to strike a balance between processing complexity and performance improvement. Additionally, spatial processing techniques based on orbital angular momentum (OAM) could potentially enhance various factors in 5G, including capacity, efficiency, and coverage

4.1 Massive MIMO

Original Multi-Channel Time-Domain Processing (MIMO) is a type of multi-channel time-domain processing that mainly uses the baseband. However, 4G MIMO uses multiple antennas at both transmitter and receiver sides to multiply the capacity of a radio link. This allows a base station to simultaneously serve multiple users using the same time-frequency resource. Massive MIMO expands on MIMO by dramatically increasing the number of antennas used at the base station, increasing spectral efficiency and SINR. Channel estimation, signal detection, pre-coding, and pilot contamination reduction are the main aspects of signal processing in massive MIMO. The key to implementing massive MIMO in 5G is ensuring effective implementation of these large-dimensional matrix computations in real-similar systems. A promising architecture is the reconfigurable computing array, which can perform matrix computations in a manner as good as ASIC, flexible as FPGA/DSP, and easy as C language.[2]-[4]

4.2 3D Beamforming and Diversity

Beamforming is a spatial signal processing technique that uses multiple antennas to change the beam pattern and steer it in a specific direction, increasing signal-to-noise ratio (SINR). [5] with diversity technology, multiple antennas are used at the receiver side, and spatial filtering is introduced to optimize reception in noisy and mobile environments. 3D beamforming, which includes both elevation and azimuth planes, can improve performance at the cost of increased processing complexity. In a 5G system, it can increase user capacity, coverage, spectral and energy efficiency, and reduce inter-cell and inter-sector interference. 3D techniques also provide more flexibility in antenna

array design and configuration, including planar, circular, spherical, cylindrical, uniform, non-uniform, and end-fire topologies. The order of processing units greatly reduces processing complexity, resulting in a more efficient system.[6]- [10].

Beamforming and diversity processing mainly involves matrix (vector) multiplication units, filtering units, and IFFT/FFT units. These main processing units have linear properties; thus, changing the order of these processing units does not affect system performance but greatly reduces processing complexity. Fig. 1 shows a post FFT diversity scheme where MFFT operations need to be performed and $N \times M$ unknown coefficients need to be estimated. The number of antennas is given by M , and the length of the FFT is given by N . As in Fig. 3, when the order changes, the number of unknown variables is given by $N + M$, which is a large reduction the $N \times M$ unknown variables in the original postFFT scheme. Furthermore, only one FFT operation is needed when the order is changed instead of M FFT operations for the post FFT scheme (Fig. 2). Using the cumulative and distributive properties of linear processing, the output is the same for these two schemes.

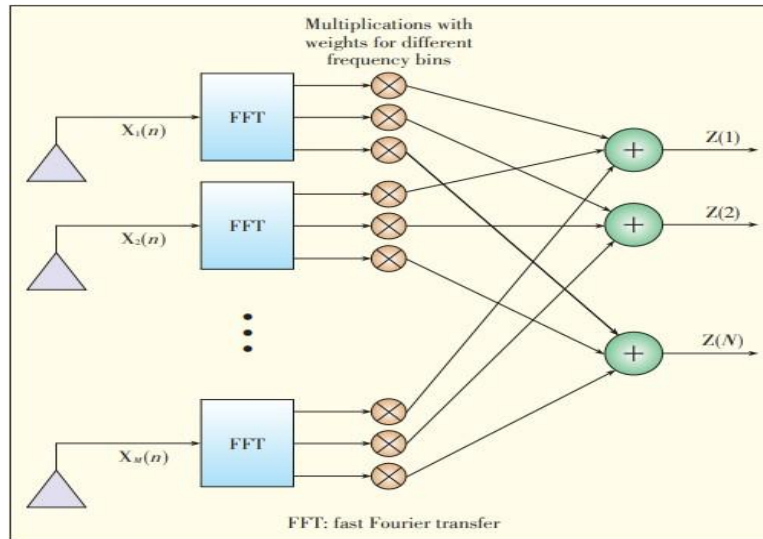

Figure 2: A post FFT diversity scheme.

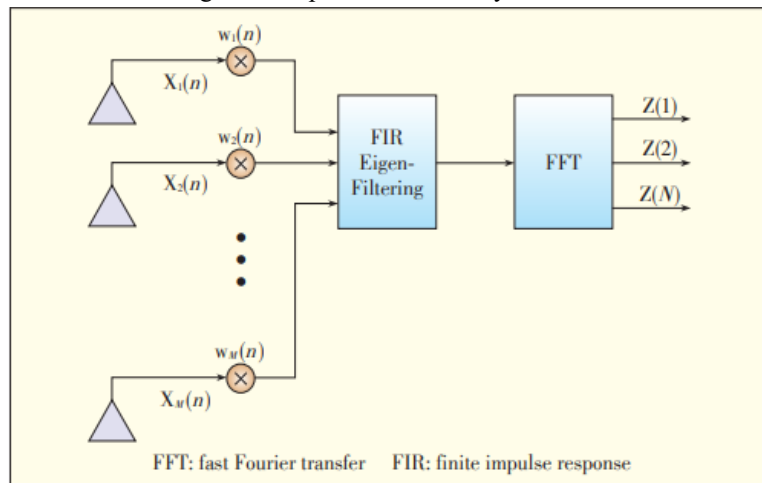

Figure 3: Version of the postFFT scheme with order changed.

4.3 OAM

OAM-based spatial processing is a new tool for increasing capacity, spectral efficiency, scalability, and decreasing channel interference in a 5G system. It uses spin angular momentum (SAM) and orbital angular momentum (OAM) in electromagnetic fields. OAM beams can carry independent data streams, increasing capacity and spectral efficiency.[12] They are also orthogonally distributed, reducing channel interference and crosstalk. OAM-based spatial multiplexing has shown benefits for wireless communication in the millimeter wave band, but extensive research is needed before it is included in 5G standards.[10]

4.4 PAPR

In 5G communication systems, Peak-to-Average Power Ratio (PAPR) reduction techniques are vital for optimizing power efficiency and mitigating signal distortion. PAPR reduction addresses the challenge of high peak power levels compared to average power in digital communication signals. High PAPR can lead to non-linear distortion in power amplifiers and reduced spectral efficiency. The elevated spectral efficiency characteristic of signals utilizing the OFDM technique presents several drawbacks, constraining its application in 5G networks. Addressing the need to diminish hardware costs associated with terminal equipment in 5G network elements, while also accommodating the introduction of new signals serving similar functions, encounters challenges such as a high Peak-to-Average Power Ratio (PAPR) and an escalation in Error Vector Magnitude (EVM). This article delineates the practical implementation of signals earmarked for adoption in the 5G standard on USRP-2943R and FPGA Kintex-7 platforms. It elucidates available strategies for mitigating peak-factor signals with concurrent elevation in out-of-band emissions, leveraging innovative signal generation methodologies to attain enhanced performance gains.[11]

5. Challenges and Opportunities

The Several critical aspects of signal processing in 5G networks. Firstly, it associated with utilizing millimeter-wave (mmWave) spectrum, noting its vast bandwidth potential but also its limitations in coverage and susceptibility to block-ages. Overcoming these challenges requires innovative signal processing techniques for beamforming, beam tracking, and obstacle mitigation. Secondly, the review addresses the complexity of interference management in 5G networks, emphasizing the need for dynamic interference mitigation techniques to optimize spectrum usage amidst the proliferation of devices and services. However, developing adaptable algorithms capable of addressing dynamic interference scenarios remains a significant challenge. Thirdly, the review discusses the imperative of supporting massive connectivity and Internet of Things (IoT) devices in 5G networks, stressing the importance of efficient signaling protocols, resource allocation schemes, and energy-efficient signal processing techniques to accommodate the diverse communication requirements of IoT applications. Additionally, the review highlights the critical role of signal processing in reducing latency for latency-sensitive applications, ensuring security and privacy in data transmission, maximizing energy efficiency, integrating with emerging technologies, and ensuring standardization and inter-operability across diverse 5G deployments. Addressing these challenges and leveraging opportunities in signal processing is essential for unlocking the full potential of 5G technology to drive innovation, economic growth, and societal progress.

6. Conclusions

The rapid evolution of wireless communication technologies has propelled 5G to the forefront of the telecommunications landscape, promising transformative capabilities that have the potential to revolutionize numerous industries and empower a wide array of applications. Throughout this review, underscores the need for advanced modulation and signal processing techniques to meet the demands of 5G communication systems. While OFDM and OFDMA have limitations, newer schemes like GFDM, FBMC, UFMC, BFDM, SCMA, and NOMA offer improved spectral efficiency and resilience to interference. Spatial-domain processing techniques such as massive MIMO, 3D beamforming, and OAM-based spatial processing are also highlighted for their role in enhancing system capacity and efficiency. Additionally, the paper addresses the challenge of PAPR reduction in 5G systems, emphasizing the importance of efficient power management. Overall, these advancements are crucial for enabling higher data rates, lower latency, and improved performance in 5G networks.

7. References

- [1]. F.L. Luo, W. Williams, M. R. Rao, et al., Trends in signal processing applications and industry technology, IEEE Signal Processing Magazine, vol. 29, no.1, pp.174-184, Jan. 2012. doi: 10.1109/MSP.2011.943129.
- [2]. E. G. Larsson, O. Edfors, F. Tufvesson, and T. L. Marzetta, "Massive MIMO for next generation wireless systems," IEEE Communications Magazine, vol. 52, no. 2, pp. 186-195, Feb. 2014. doi: 10.1109/MCOM.2014.6736761.
- [3]. F. Rusek, D. Persson, B. K. Lau, et al., Scaling up MIMO: opportunities and challenges with very large arrays, IEEE Signal Processing Magazine, vol. 30, no.1, pp. 40-60, Jan. 2013. doi: 10.1109/MSP.2011.2178495.
- [4]. Robert W. Heath; Nuria Gonzalez-Prelcic; Sundeep Rangan; Wonil Roh; Akbar M. Sayeed, An Overview of Signal Processing Techniques for Millimeter Wave MIMO Systems," IEEE Journal of Selected Topics in Signal Processing, vol.10, April 2016. DOI: 10.1109/JSTSP.2016.2523924
- [5]. Muhammad Farhan Khan; Dirk Pesch, On Performance of multi- user Massive MIMO for 5G and Beyond, 2022 IEEE 95th Vehicular Technology Conference: (VTC2022-Spring). DOI: 10.1109/VTC2022-Spring54318.2022.9860567
- [6]. Gordana Barb; Marius Ottesteanu; Florin Alexa; Ana Ghiulai , Digital Beamforming Techniques for Future Communications Systems, 2020 12th International Symposium on Communication Systems, Networks and Digital Signal Processing (CSNDSP).DOI: 10.1109/CSNDSP49049.2020.9249607
- [7]. S. Mohammad Razavizadeh, M. Ahn, and I. Lee, Three dimensional beam forming: a new enabling technology for 5G wireless networks, IEEE Signal Processing Magazine, vol. 31, no.6, pp. 94- 101, Nov. 2014. doi: 10.1109/MSP.2014.2335236.
- [8]. M.T. Dao, V.A. Nguyen, Y.T. Im, et al., 3D polarized channel modeling and performance comparison of MIMO antenna configurations with different polarizations, IEEE Transactions on Antennas and Propagation, vol. 59, no. 7, pp. 2672-2682, Jul. 2011. doi: 10.1109/TAP.2011.2152319.
- [9]. Sasi.A; Jaya J, Multilevel Optimized Technique For 5G , 2020 6th International Conference on Advanced Computing and Communication Systems (ICACCS). DOI: 10.1109/ICACCS48705.2020.9074419.



- [10]. Madiha Showkat; Javaid A. Sheikh; Arshid Iqbal Khan, A New Beamforming Technique in 5G Environment for Reliable Transmission, 2018 4th International Conference on Computing Communication and Automation (ICCCA).DOI: 10.1109/CCAA.2018.8777661.
- [11]. G. Timoshenko; N. K. Osipenko; A. A. Bakhtin; E. A. Volkova, 5G Communication Systems Signal Processing PAPR Reduction Technique, 2018 Systems of Signal Synchronization, Generating and Processing in Telecommunications (SYNCHROINFO).DOI: 10.1109/SYN-CHROINFO.2018.8456989.
- [12]. O. Edfors and A. J. Johansson, Is orbital angular momentum (OAM) based radio communication an unexploited area? IEEE Transactions on Antennas and Propagation, vol. 60, no.2, pp. 1126- 1131, Feb. 2012. doi: 10.1109/TAP.2011.2173142.
- [13]. K. Selvam; K. Kumar , A novel Energy-efficient Resource Allocation algorithm for Non-orthogonal Multiple Access (NOMA) based M2M communication, Institute of Electrical and Electronics Engineers (IEEE), 2020.
- [14]. Saurabh Srivastava; Prajna Parimita Dash , Non-Orthogonal Multiple Access: Procession towards B5G and 6G , 2021 IEEE 2nd International Conference on Applied Electromagnetics, Signal Processing, Communication (AESPC).DOI: 10.1109/AESPC52704.2021.9708494.
- [15]. A Sathishkumar; Sankararao Majji; Tulasi Radhika Patnala; Santoshachandra Rao Karanam; Ashok Kumar; Mula Malyadri, 'Experimentation Methodology of Orthogonal Frequency Division Multiplexing Signals Process using Radio over Fiber (RoF) system" , 2022 International Virtual Conference on Power Engineering Computing and Control: Developments in Electric Vehicles and Energy Sector for Sustainable Future (PECCON).DOI: 10.1109/PECCON55017.2022.9850996.
- [16]. G. Fettweis, M. Krondorf, and S. Bittner, GFDM generalized frequency division multiplexing, in Proc. IEEE 69th Vehicular Technology Conference, Barcelona, Spain, Apr. 2009, pp.1-4. doi: 10.1109/VETECS.2009.5073571.
- [17]. B. Farhang Boroujeny, OFDM versus filter bank multicarrier, IEEE Signal Processing Magazine, vol.28, no.3, pp.92- 112, May 2011. doi: 10.1109/MSP.2011.940267.
- [18]. F. Schaich and T. Wild, Waveform contenders for 5G: OFDM vs. FBMC vs. UFMC, in Proc. 6th International Symposium on Communications, Control and Signal Processing, Athens, Greece, May 2014, pp. 457-460. doi: 10.1109/ISCC SP.2014.6877912.
- [19]. M. Kasparick, G. Wunder, P. Jung, et al., Biorthogonal waveforms for 5G random access with short message support, in Proc. 20th European Wireless Conference, Barcelona, Spain, May 2014, pp. 1-6.
- [20]. H. Nikopour and H. Baligh, Sparse code multiple access, in Proc. IEEE 24th International Symposium on Personal Indoor and Mobile Radio Communications, London, United Kingdom, Sept. 2013, pp. 332- 336. doi: 10.1109/PIM RC.2013.6666156